



# Pneumatic Stencil Cleaning Machine

**Model: S-1688**

# Operation & Maintenance Manual



V3.01

---

# CONTENTS

## **1 Introduction**

- 1.1 Introduction range
- 1.2 Guidance to read
- 1.3 Chemicals

## **2 Safety**

- 2.1 General guidance
- 2.2 Magnetic field
- 2.3 Safety Rules
- 2.4 Maintenance Safety indication
- 2.5 Safety operation actions
- 2.6 Safety and protection devices
- 2.7 Safety signs
- 2.8 Safety procedure
- 2.9 Personal Protection
- 2.10 Danger
- 2.11 Personal injury accident
- 2.12 Emergency procedure
- 2.13 Owner's responsibility
- 2.14 Operator and maintenance staff responsibility
- 2.15 Design request
- 2.16 Maintenance and repair
- 2.17 Clean machine and material treatment
- 2.18 Machine control
- 2.19 Machine structure change

## **3 Machine overview**

- 3.1 Working principle
- 3.2 Structure characters
- 3.3 Pneumatic control characters
- 3.4 Spray clean filter system features
- 3.5 Basic spec
- 3.6 Clean procedure
- 3.7 Machine unit introduction

## **4 Installation and adjust**

- 4.1 Preparations before installation
- 4.2 Installation steps
- 4.3 Machine adjust
- 4.4 Clean mode and precautions

## **5 Operation instruction**

- 5.1 operation panel
- 5.2 Start operation
- 5.3 Manual liquid add in
- 5.4 Manual liquid discharge
- 5.5 Clean tank and filter
- 5.6 Air supply
- 6 Maintenance**
  - 6.1 Maintenance sheet
  - 6.2 Maintenance precautions
  - 6.3 Maintenance cycle sheet
- 7 Trouble shooting**
  - 7.1 Rotary spray device
  - 7.2 Clean system
- 8 Parts sheet**
  - 8.1 Pneumatic control parts
  - 8.2 Pipe main parts
- 9 Warranty terms**
  - 9.1 Warranty time
  - 9.2 Warranty items
  - 9.3 Instructions
- 10 Service range**
- 11 Appendix**
  - 11.1 structure drawing
  - 11.2 Liquid chart

# 1 Introduction

## 1.1 MANUAL RANGE :

This manual introduce“S-1688 Pneumatic Stencil Cleaning Machine” operation, maintenance and spare parts in details. It has 11 chapters and the full content of each chapter is listed on the relevant “contents”. Other important information such as: Machine serial no and clean process steps also included in the first page. (Nameplate)

## 1.2 Guide:

Guided reading refers to the relevant chapters, find what you need and instructions, and follow the instructions.

## 1.3 Chemical Solutions:

The following documents relate to the supplied chemical syrup. They are not part of the content of this file:

- \* Chemical Solution Safety Meter
- \* Instructions for the use of chemical solutions\*
- \* Analysis Program

# 2. Security:

## 2.1 General Description

- \* This file contains information about how to safely operate and repair S-1688 the important information of the full pneumatic steel net cleaning machine.
- \* For safe and no violations S-1688 full pneumatic steel net cleaning machine, must thoroughly



## Shenzhen Southern Machinery Sales And Service Co. Ltd

Add:Rm1806,Block3,JinyunCOFCO,Qianjin-2<sup>nd</sup>Road,Xixiang,Baoan,SZ,518102,China  
TEL: 0755-83203237; Email:info@smthelp.com; Website:www.smthelp.com

---

understand safety instructions and regulations.

\* All work or actions S-1688 all pneumatic steel net cleaning machine must follow the safety instructions and regulations in this document.

\* In addition, please obey the local regulations on accident prevention.

For your security, please read and use the instructions carefully before you operate the machine!

Shenzhen Southern Machinery Sales And Service Co. Ltd. reminds customers that the operation of the machine must be carefully and completely read this manual, and in strict accordance with the provisions of this specification for standardized operation. In particular, the contents of section "Security" in the section 2 of this manual must be paid attention for MT does not incur any joint or several liability for losses resulting from non-compliance with the requirements in the operating instructions.

Use the instructions in this operation manual:

This specification contains S-1688 all pneumatic steel net cleaning machine users required information.

- \* Quick familiarity with machine usage
- \* Operate the machine correctly
- \* Working procedure for cleaning safely
- \* Maintenance and maintenance of machines
- \* Troubleshooting

The instructions for this operation are based on the design criteria for S-1688: if there are specific modifications, the criteria will not change accordingly.

The installation and debugging of the S-1688 full pneumatic steel net washer must be done by a professional or authorized technician by MT. After commissioning, the cleaning equipment user or agent will accept operation and safety requirements of the theory and practice training. Any switch operation or parameter adjustment shall be strictly prohibited before the equipment is formally transferred to the user.

Note:

If the contents of this specification are not understood, please contact the MT Contact. We will quickly

---

explain and modify the file accordingly to prevent erroneous operation due to incorrect understanding.

Users in the process of operating the machine should comply with the content of this specification, such as with the technical staff to guide the contradiction; to The MT technician's guidance is accurate.

## **2.2 Magnetic Field**

For most people, these magnetic fields are harmless. But for some specific medical devices, the magnetic field has potential hazards. Individual own pacemakers, implanted defibrillators, other medical electronic devices, metal heart valves, internal wound clamps (surgical), metal devices or sickle cell blood disease will not be in the vicinity of the magnetic field around the pump. If you have one of these, please consult your health care department for special advice before you work on the magnetic field.

## **2.3 Security Rules**

**2.3.1 Stability:** To ensure the safe operation of the machine, the machine should be placed on the ground smoothly;

**2.3.2** If you need to move the machine, avoid crashing the machine and causing damage to the internal structure of the machine;

**2.3.3** In the installation of gas source, please pay attention to the gas source specifications are in line with the use of the gas source specifications, to avoid the coherent caused by machine damage;

**2.3.4** Air pump should be grounded: in the relevant phase line must be equipped with a grounding wire, and with "PE" flag, before the boot, must ensure that "PE" grounding terminals are grounded and good connection;

**2.3.5** Air Control box door affixed with safety markings, this part of the air control system, not professional do not open;

**2.3.6** Machine affixed with a protective flag, indicating that when the machine is working, there will be a certain hazard, please understand the meaning of the logo, to prevent causing harm;

**2.3.7** Do not arbitrarily adjust internal settings, such as the need to adjust internal settings, please inquire first with the MT technical personnel to negotiate to avoid inconvenience of use;

**2.3.8** Keep the workspace clean and unobstructed: messy work areas and countertops are easy to cause accidents and should be clean and tidy;

**2.3.9** Wear the right dress: operators do not wear too loose clothes, do not wear ties, rings, bracelets, the work area must wear non-slip shoes, if left long hair must wear a hat;

---

**2.3.10** Remain vigilant: pay attention to what you are doing, and when you are tired, stop working on the machine immediately;

**2.3.11** Pay attention to maintenance and maintenance machine: The machine must be in strict accordance with the instructions and factory specifications for regular and effective maintenance and dimension.

Maintain good performance and state of the machine;

**2.3.12** Use the correct tool: Please use specialized tools to repair the machine, to avoid affecting machine performance and service life;

**2.3.13** Prohibit the use of machines in humid and murky environments: do not use machines in wet places or expose them to rain.

The working area should be kept bright to ensure adequate light intensity during operation and maintenance;

**2.3.14** Prohibit removal of any parts of the machine: Before starting, to form the habit of checking the machine, look at the various parts on the machine whether the parts remain in place;

**2.3.15** Prohibits non-native operators, unauthorized personnel and any pets approaching the machine: all non-native operators are not allowed to operate the machine.

Authorized personnel and any pet should stay away from the work area and keep a safe distance from the machine;

**2.3.16** Forbid personnel to stand on the machine: Do not crawl on the machine at will, if the machine is dumped or the gas source is accidentally connected.

Can cause serious damage, before opening the gas source switch, should ensure that all personnel and the machine to maintain a safe distance;

## 2.4 Maintain security instructions

If the machine works under normal conditions and is well maintained, it can effectively prolong the machine and service life of components.

**2.4.1** The machine must be maintained and maintained by a designated professional, if the replacement accessory must be used by the designated professional to use the original accessories.

Line Repair;

**2.4.2** Carefully maintain the machine, carefully check each part of the machine, eliminate the potential danger in time, keep tool sharp, clean, to maximize efficiency, ensure maximum security;

**2.4.3** Check the repaired parts or devices before starting again, you should carefully check the repaired parts or devices to determine whether it can use for normal operation, whether it can play the expected function, check whether the transmission part is right and strong, to exclude any influence possible factors for normal machine operation, should be replaced in a timely manner for damaged protection devices or parts;

**2.4.4** Waste Gas treatment should comply with local laws and regulations, and give high priority to the maintenance of waste water should be properly handled.

Note: Means to protect the environment.

## 2.5 Safe Working behavior

Authorized or skilled operator to use this machine

### 2.5.1 Operator Training

In the use, operation and adjustment of the machine, operators must be trained, in particular to fully understand the following aspects:

- A. The machine may be in danger of running.
- B. The principle of the machine, the correct use method.
- C. Function settings for the machine.

Only those who have read and understood the instructions and are designated by the manufacturer and trained are allowed to operate the machine.

Only 18 years old and above personnel is allowed to operate this machine independently.

**2.5.2** Machine work requires staff to have different qualifications, see table:



Work Content	People who have been instructed (with professional qualifications *)	Engineering Technicians who have been instructed
Assembly and Installation	can only be done by SM personnel or authorized professional	
Commissioning and trial operation	can only be done by SM personnel or authorized professional	
Start, run, stop	√	√
Machine work: troubleshooting, repair and maintenance		√
Disassembly	can only be done by SM personnel or authorized professional	

**2.5.3** Professionals are those who, based on their accepted technical training, knowledge and experience, and knowledge of the relevant provisions, can assess the person who gave him work and was aware of the risks that might occur.

The manufacturer must instruct and inform the staff of the following information:

- \* Possible danger, dangerous consequences and prevention.
- \* Take safety measures against machines in dangerous situations.
- \* Use of personnel protection facilities.
- \* Security equipment.
- \* Comply with operational requirements.
- \* Malfunctions and problems that may occur with the machine.
- \* How to use tools correctly.

Personnel who do not possess this knowledge or do not operate the machine correctly shall not operate the equipment.

If with SM agreed Maintenance Contract, only SM or fully qualified personnel are allowed to perform maintenance and repair.

## 2.6 Security and protection appliance :

- \* You must ensure that all safety and protection devices are properly installed and working well before the machine starts.
- \* Safety and protection devices can be removed only if the following conditions are available.

-The machine was completely stopped.

-Make sure that the machine cannot be restarted.

\* Customer only installs security and according to the specified protection device, otherwise SM will not provide components.



### 2.6.1 Emergency stop switch:

- \* The emergency stop switch is installed on the operating surface of the machine.
- \* The emergency stop switch is mounted on the yellow base and has a red contact device.
- \* Emergency stop switch in accordance with EU CE and other requirements are manufactured.
- \* The emergency stop switch will be implemented to shut down all control systems; all pumps and other switches will be closed.

## 2.7 Security Flag

The following signs are affixed to the machine. These signs should be inspected regularly and should not be clearly legible. The table is a full label on the machine.

Require attention and protection when you operate or maintain the machine.

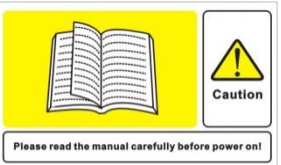
 <p><b>No Flame</b></p>	<p>Flammable signs: This sign requires that you place the appliance away from sources of ignition. Pay attention to the flammable products of fire prevention, so as to avoid fire.</p>
 <p><b>Wearing your labor-gloves!</b></p>	<p>Protection mark: This mark prompts you to wear industrial rubber protection during the operation of the equipment Gloves.</p>
 <p><b>Wearing your goggle before operation!</b></p>	<p>Protection mark: This mark prompts you to wear industrial eye protection during equipment operation Eye Protection Glasses.</p>
 <p><b>Please read the manual carefully before power on!</b></p>	<p>Manual logo: This symbol is to prompt you to operate this equipment, please read carefully before operation As instructions.</p>

## 2.8 Security Program

### 2.8.1 Overview

MT devices are manufactured in accordance with the latest technical standards and mainstream safety practices, but may have health risks and practices during operation.

The author's or third party security issues, as well as possible damage to machine damage or other parts.

The MT device can only be used for:

- \* Within its own design range.
- \* When the relevant functions of all safety equipment work properly.
- \* Security-related deficiencies must be addressed immediately.
- \* This file must be located near the device.
- \* In addition to this document, regulations on local accident prevention and environmental protection should also be attached.
- \* All security warnings and text labels on the device should remain legible and readable.

### 2.8.2 Normal operating security

- \* Check before the device is started to ensure that no one is in danger when the device is started.
- \* The device can be started only if all the security and protection devices are in normal working order.
- \* Do not operate the device without any protection cover being removed.
- \* Do not install or change the wiring of the security device.
- \* Check and confirm the emergency stop switch and visible equipment damage at least at each shift.
- \* All operators must know the emergency stop switch, the main control system switch and the machine's chemical solution shutoff valve location.
- \* Always keep clothes and body away from moving parts of the device.
- \* Always wear protective glasses when working around the machine.
- \* When working in a chemical solution, always put on the appropriate protective clothing.
- \* Do not manually mix chemicals in the liquid tank of the device, and some chemicals will release dangerous heat to harm people or equipment.
- \* The designated responsible person must confirm that all interconnecting devices on the equipment, protective devices and ventilation devices are working properly.
- \* Do not operate at a temperature that is not suitable for structural materials.

### 2.8.3 Air Control system security program

- \* Only trained personnel can be allowed to work in an air control system.
- \* Must have regular inspection equipment's air control system, the connector loosening and the line

---

damage must be repaired in time.

- \* The control box should always be locked and only authorized personnel are allowed to open it.
- \* It is necessary to wear live safety equipment at work and must read safety rules.
- \* Ensure that tools or metal objects are not left in the equipment or control box

#### **2.8.4 Chemical Liquid Safety Program**

The chemical solution used by the device must comply with all instructions including safety information, operation manuals, and analysis procedures.

- \* You must wear appropriate protective clothing when working in a chemical environment.
- \* All chemical solutions in the equipment must be handled in accordance with the relevant safety procedures and regulations.
- \* Maintenance personnel must be able to enter the work after emptying and cleaning the tank.
- \* Maintenance personnel must be able to work without pressure in the pipeline.
- \* When sampling is required for analysis, the protective clothing must be worn and the drive and pump must be closed.
- \* Do not manually mix chemicals in the liquid tank of the equipment, and some chemicals will release the damage caused by hazardous heat.
- \* Do not use any chemical or concentrated chemicals that do not conform to the structural material.

#### **2.8.5 The security program for the exhaust air.**

- \* If there is no proper exhaust system, dangerous exhaust air will be released.
- \* Special Personal protective equipment is placed in the fixed area to deal with the release of such exhaust air.
- \* The exhaust system shall be regularly inspected in accordance with the regulations.
- \* Verify that the exhaust system should be checked along the pipeline for each independent vent connection point.

#### **2.8.6 Internal part of the security program**

Open all S-1688 covers or doors on the whole pneumatic steel net washer, and enter the inner area of the device;





- \* Read the chemical solutions manufacturer's data sheet on raw materials safety.
- \* Follow the recommended procedures for chemical solutions manufacturers.
- \* Understand the emergency procedures in your factory.
- \* Turn off the transmission system for the device.
- \* Close the cleaning pump for the equipment.
- \* Wait 2 minutes to allow the solution to flow back to the liquid trough from the internal surface.
- \* Take the protective devices recommended by the manufacturer of chemical solutions such as goggles,

gloves, aprons and respirators.

- \* Move off S-1688 lid or door of the full pneumatic steel net washer.
- \* Re-cover the lid or door when you do not need to go inside.
- \* Restart the device according to the factory operating procedure.

## 2.9 Personnel protection

Staff must use qualified anti-corrosion gloves, glasses, masks and other safety aids, or suitable safety equipment. During machine operation, wear the following items:

	Electrostatic clothing can prevent static electricity
	Gloves to prevent chemical cleaning fluid on the human hand injury
	Static shoes can prevent static electricity
	Masks to prevent chemical cleaning fluid on the human respiratory system damage

## 2.10 Danger

### 2.10.1 Risk of liquid pressure:

1. Must obey the hydraulic system maximum working pressure. Excessive pressure will have a great damage to the pressure component(s) and may make the hydraulic system burst.
2. Liquids can be dangerous in overpressure conditions.
3. Open the hydraulic control valve and release the system pressure before working on the hydraulics system.
4. Maintain the equipment to place the channel, air flow smoothly. Do not store items around the top or vent of the device!
5. Cleaning fluid is a chemical substance that causes allergic reactions after prolonged exposure to the skin. Can cause certain harm to the contact person.



When touching liquids; comply with the personnel protection instructions in this manual.

Before starting the maintenance, inspection and repair work, confirm that there is no residual liquid in the pipeline. Liquid may leak, leaks may cause environmental hazard. Comply with the liquid manufacturer's safety parameter table.

### 2.10.2 Fire Hazard

1. When the fire is on, stop the equipment immediately (press the emergency stop button or cut off the input gas source), and immediately exit from the emergency exit and immediately alarm, keep equipment under isolation.
2. If there is a fire hazard, use factory-equipped fire-fighting equipment for fire suppression.
3. When extinguishing, always keep a safe distance from the fire.

## 2.11 Personal Injury incident :

1. Shut down the device immediately.
2. Emergency Relief / First aid.
3. Protect the injured person and place it in a stable place.
4. Call First aid via telephone or radio communication equipment: Fire brigade, Rescue Service (doctor).
5. Concise accurate description of the details.

- \* Your phone number
- \* Your name
- \* The order in which the emergency occurred
- \* Accident location
- \* Number of injured persons
- \* Injury category
- \* Precise position indication

### 2.11.1. Ensure that your call is fully understood by your rescue service staff.

1. Notify the company admin owner
2. Comply with the onsite rescue plan
3. Display warning signs on site, use rescue equipment to start rescue. (if necessary)
4. Keep access to the live channel

### 2.11.2 Can be dangerous during machine work. Machine operation must be only:

- \* Use for specified purposes
- \* Is not in Technical Failure Status
- \* Users are aware of safety precautions and hazards
- \* In case of machine failure, preventive security must be immediately excluded

## 2.12 Emergency Procedures :

---

### 2.12.1 Overview

The definition of an emergency is a situation where a person's injury or equipment damage occurs.

1. Press the Emergency stop button, close device. Make sure that the device does not start again.
2. If a person is injured, immediately take medical and firefighting assistance.
3. Determine the extent and type of emergency.
4. Correct the cause of the emergency.
5. After completely correcting the cause, restart the device. Rotate the emergency stop button clockwise and unlock the emergency stop button.

### 2.12.2 Behavior (Spray rotation device jammed or choked)

If a stuck situation occurs:

1. Use the emergency stop button to stop the system.
2. Observe where the card is stuck.
3. Relevant personnel to wear protective clothing or protective devices.
4. Remove the protective cover from the jammed rotary machine.
5. Check whether the mechanical parts of the card area, such as bearings, are properly placed, intact or worn.
6. Check the mechanical parts to ensure they are in the correct position.
7. Reset the rotation mechanism.
8. Restart the machine according to the related program.
9. When the occurrence of jam, chemical spills must be cleaned from equipment area.

### 2.12.3 Behavior (Clothing or body parts wrapped in moving parts)

If the clothing or part of the body is entangled with the moving parts of the device:

1. Use the emergency stop button to stop the machine.
2. To assist the person who is entangled with the device in accordance with the appropriate emergency procedures.
3. Turn off the device's pneumatic control switch as soon as possible after completing step 2.

### 2.12.4 Behavior (People exposed to chemical solutions)

Where a person is exposed to a chemical solution: (Produced by a pipe rupture or other deformation)

1. Use the Stop button to stop the system.
2. Assist the person who is exposed to the chemical solution in accordance with the appropriate emergency procedures.

- 
3. The main air control switch can be turned on until the proper maintenance is completed.

### 2.13 Owner's Responsibility

The owner has the responsibility to allow the following personnel to operate and maintain the machine;

- \* Fully qualified and trained personnel to operate or repair the machine.
- \* Fully understand the safety and accident prevention personnel.
- \* People who have read and understood this security operation section and security instructions.
- \* Personnel familiar with operational and work safety should be subject to periodic audits.
- \* All machine safety devices should be inspected regularly.
- \* The owner shall provide the necessary personnel protection device and equipment operation training.

### 2.14 Operations and maintenance personnel responsibilities

All operations or maintenance personnel have the following responsibilities:

- \* Strictly abide by work safety regulations and accident prevention measures.
- \* Read the safety section and safety instructions for this instruction sheet.

### 2.15 Design Requirements

The MT-2750 full pneumatic steel net cleaning machine is designed separately for the cleaning of the electronic industry Net board. The use of other devices or beyond specifications is not recommended and is beyond the design scope of the device itself.

If there are any such cases, MT will not be responsible for any loss or loss of productivity caused by the misuse of the device.

In addition, proper use of equipment includes:

- \* Follow all instructions in the file.
- \* All necessary inspection and maintenance work should be carried out in strict compliance with the equipment maintenance schedule.

### 2.16 Maintenance and Repair

- \* Must follow the maintenance schedule to implement the required assembly, maintenance and



---

inspection work, please refer to section 6.3 paragraph.

\* Must be closed before any maintenance, repair or inspection work done with S-1688 all pneumatic steel net washer.

- Close and lock the main air control switch
- Take the key (if any)
- Notify Machine operators
- Post a warning mark to prevent the switch from being opened

\* Use a lifting device when you need to replace large or heavy parts.

\* Check the fasteners for loose connection screws.

\* When the maintenance is finished, check that all the safety and protection devices are working properly.

## 2.17 Cleaning equipment and materials handling

\* Recommended Use WD40 or dust-free cloth to clean the surface of the equipment and water-free area.

\* Internal cleaning, rinse area use DI water rinse.

\* All materials must be processed in accordance with relevant regulations and procedures.

## 2.18 Device Control

\* You cannot change the control program under any circumstances.

\* Only trained and authorized personnel can operate on the control part.

## 2.19 Device Construction Changes

\* Do not change or change the equipment, including the supporting parts of the welded structure, except in advance of the manufacturer's permission.

\* All modifications must be obtained MT written confirmation.

\* Directly replacing any part on the device is not the correct way to work.

\* Only use the spare parts provided by the original.

If the spare parts are from except vendors other than SM. SM will not guarantee these spare parts in accordance with the security requirements specified by SM.

---

## 3 MACHINE OVERVIEW:

### 3.1 WORKING PRINCIPLE

This machine is a new type, high performance, pneumatic SMT stencil cleaning system which driven by compressed air. Both solvent and water base detergent can be used on this machine.

Put stencil into cleaning room manually, set clean and dry time, close front doors, push “Start” key, Machine will start to clean and dry. When setting clean and dry time is running up, the machine will stop automatically. Open the front doors to reset the machine for the next clean cycle.

Clean liquid used repeatedly in the machine to save cleaning liquid consume amount and cost; Shorten cleaning time; Avoid the time for operator to contact cleaning liquid directly to protect them. This machine only use compressed air as power, not use electric power at all, so it can guarantee 100% safety, not matter solvent or water base detergent you use. All parts using in this machine are famous brands, design and manufacture process are very strict, so it is high quality, stable, long lifespan and very few after-sales service. The exhaust air during dry process will be sent out through its inner special vent structure, this makes less liquid cost and very few liquid smell to give off.

### 3.2 MACHINE STRUCTURE FEATURES

- 1) This machine use 2 layers door with seal strip design, good seal performance helps to reduce liquid smell and liquid give off significantly ;
- 2) Liquid observation window and liquid level—very convenient for the operator to watch the change of the liquid level and liquid situation;
- 3) Made up of SUS304 steel, resist corrosion of acid and alkali liquid;
- 4) Stable and smooth rotation spray design, excellent cleaning performance;
- 5) Clean liquid pressure can be adjust and watched on the panel pressure meter, right for all kinds of stencils.
- 6) Special vent device design, less liquid consumption.
- 7) Sound insulation cotton on machine doors—reduce noises give off by air pump, improve cleaning workshop noise pollution ;
- 8) Tilt cleaning room bottom design— no liquid keep in cleaning room, convenient to clean cleaning room.

---

### 3.3 PNEUMATIC CONTROL FEATURES

- 1) Control box control all the machine actions which on the right side of machine—convenient to operate and fix;
- 2) Using mechanical Timer control time -- easy operation, easy training;
- 3) Indicators and pressure meters --ensure operator to know the machine working situation exactly. If there is any abnormal situation happens, indicator will turn red and pressure meter will not indicate the right pressure;
- 4) Front door safety protection valve – to avoid the risk of forgetting close the front door caused by operator.
- 5) Liquid which cycle used and discharged are 3-level filtered – cost down and reach discharge requirement.
- 6) Air regulator on the rear side, air pressure can be adjusted as you need;
- 7) All pneumatic control, no fire and personal accident risk at all.

### 3.4 SPRAY CLEANING FILTER SYSTEM FEATURES

- 1) Nozzles on spray rods are installed on same 5~15°direction, spray cover all cleaning area and avoid interfere with each other;
- 2) Quick assemble SUS304 nozzles, easy to assemble, disassemble and clean;
- 3) Spray liquid pressure meter – convenient to watch and adjust suitable spray pressure;
- 4) Filter bag, filter net in the liquid tank and precise liquid filter design – keep air pump and nozzles away from block and significantly raise liquid use efficiency ;

### 3.5 BASIC FEATURES:

Stencil size: 750mm(L) × 750mm(W) × 40mm(H) as max ( bigger size should be custom made)

Liquid tank capacity: 40L ( as max )

Best liquid amount to use: 25~30L

Cleaning method: 360°rotary liquid and compressed air spray ( clean→dry )

Dry method: Compressed air blow dry

Recommend clean time: 3-10 minutes

Recommend dry time: 3-8 minutes

Clean filter: 3-level filters

1 grade : 100um (for bigger materials...)

2 grade: 50um (for labels, screws...)

3 grade: 1um (for solder paste balls)

Air supply: 0.5Mpa~ 0.7Mpa

Air consumption: 400-600L/min

Net weight: 230Kg

Vent size:  $\Phi 124(W) \times 30mm(H)$

Dimensions: 800mm(L)  $\times$  950mm(W)  $\times$  1650mm(H)

### 3.6 CLEAN FLOW CHART:

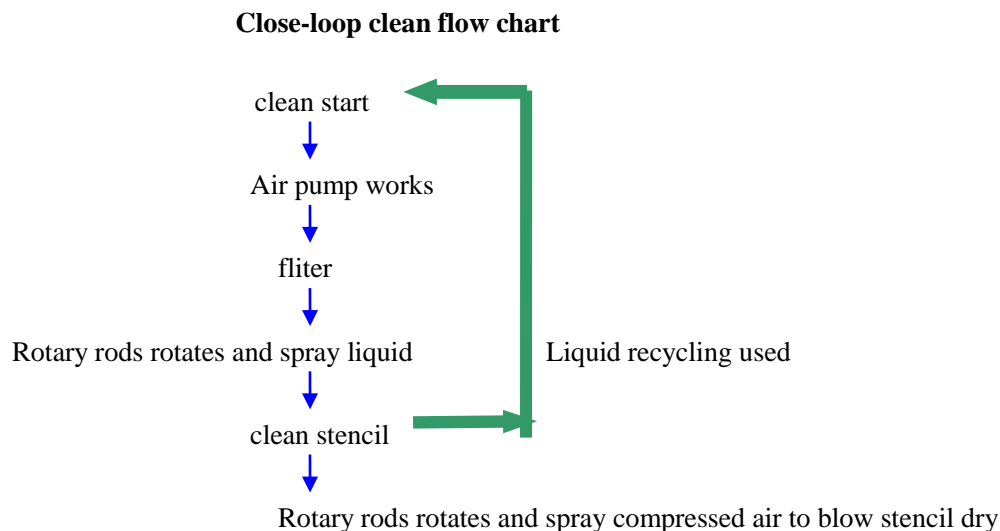

### 3.8 INTRODUCTION OF MACHINE PARTS:

- 1)、Front door situation indicator: Door closed—green, door open—red.
- 2)、Emergency Button: Installed on front operational panel. Push it when abnormal situation happens.
- 3)、Start key: Push to start to clean stencil.
- 4)、Air pump pressure meter: Display air pump pressure.
- 5)、Clean timer: Set cleaning time.



**SOUTHERN  
MACHINERY**

## **Shenzhen Southern Machinery Sales And Service Co. Ltd**

Add:Rm1806,Block3,JinyunCOFCO,Qianjin-2<sup>nd</sup>Road,Xixiang,Baoan,SZ,518102,China  
TEL: 0755-83203237; Email:info@smthelp.com; Website:www.smthelp.com

---

- 6)、Dry timer: Set dry time.
- 7)、Cleaning pressure adjust regulator: Adjust cleaning pressure of spray liquid.
- 8)、Filter: Filtering labels, solder paste balls and other materials, keep clean liquid on each clean cycle.
- 9)、Spray rods: Assemble nozzles and rotate to spray clean and dry stencil.
- 10)、Vent: Compressed air and liquid moist give off vent, need to connect outer hose.
- 11)、Clean room: Where stencil kept and 2 rotary spray device installed.
- 12)、Liquid tank: Cleaning liquid storage tank.
- 13)、Foot wheels: Support and move the machine.

---

## 4 Installation and cleaning test

### 4.1 PREPARATIONS BEFORE INSTALLATION:

Before the arrival of the machine, we will send out the installation preparations and cautious documents, please do preparation works according the requirements. Machine installation ground should be solid, flat, clean and have enough space for the convenient of connecting of main air hose, exhaust air vent and machine operation and daily maintenance.

Please check if there is any damage on the plywood case. Please take photos and inform us at the first time.

If the plywood case is good, please open the case carefully and please move the machine onto the ground by using auto forklift.

Never exposure the machine to the hot sun and rain. Never put it onto the environment of high temperature or high humidity.

1) Air supply: compressed air must be clean and free of oil. Air compress should be 0.5~0.7Mpa and air flow rate should be 400~600L/Min. Do please make sure your air supply meet the required standards.

2) There is a  $\varnothing$  125mm air vent on the top of the machine, please prepare one PVC tube or Tin tube and connect one end to the air vent by using sus304 clamp or Nylon cable tie. If the other end of the tube equipped with exhaust fan, the air speed must be under 3M/s (if there is less than 2 PCS 90°elbows, then no need exhaust fan).

Never connect the tube with other tubes with heat and fire resources, or else, it may caught fire especially when you use solvent.

3) GND (ground): please connect factory GND line to the machine GND line, so that statics on the machine may flow to the ground at any time.

4) Installation: Machine must be installed on the ground or environments listed below:

- \* Installation ground must be separate to other machines, there must be an exhaust air vent around the machine. No big electric devices around the machine.
- \* Never exposure the machine to the hot sun and keep it off the fire and heat resources devices such as heat treatment oven
- \* Please install the machine to the environment of 0~30°C、 humidity less than 85% (no dew),no corrosive and flammable gas.
- \* Please do not install the machine on the place with vibration or impact force, or else it may damage the machine.
- \* Good ventilation, dry, clean and dust free surroundings.

- 
- 5) Clean test: You can do clean test after installation work is finished. Please prepare the right clean detergent or solvent. If you use water-based detergent, please make sure it is not foam type.
- 6) Space requirement: please leave enough space for the machine installation, spare parts replace and maintenance.  
Machine outlines: 800mm(L)x950mm(W)x1650mm(H)  
Suggested space: 2000mm(L)x2000mm(W)x2000mm(H)  
Please leave about 1m space for detergent or solvent add in and discharge operation.
- 7) Stencil requirement: Normally, there are 2 types of glue used to adhere the stencil to the frame. One glue is suitable for hand wash stencil, the other is suitable for machine wash, please confirm with your stencil supplier that you are using machine to clean your stencil and ask them to use the glue which can resist the detergent corrosion.

## 4.2 Installation procedures:

- 1) Disassemble machine package and put it on to flat ground, move it to install place.
- 2) Connect vent hose: Make sure hose kept firmly and connect to vent, use strip or tape to ensure no air leak out.
- 3) Air exhaust should obey local laws and to protect environment.
- 4) Connect main air hose according to instruction of this manual and make sure the connection is right and firmly.
- 5) Check all the important parts of machine because some parts may damage during transport and installation, please pay special attention to the following aspects:
  - A Check rotary device in good condition.
  - B Check nozzles whether they are at right angles.
  - C Check no sundries in liquid tank.
  - D Check air hose connect firmly on each parts.
  - E Check all pipes connect firmly, no loose.
  - F Check each screw are tighten.

## 4.3 MACHINE TEST

### 4.3.1 Check before testing

After finishing installation, do please do the following inspection before start the machine:

- 1) Air supply pipe is suitable and connect firmly;

- 2) Exhaust hose is installed and sealed firmly;
- 3) Air supply spec is right for this machine;
- 4) All the valves are in right position;
- 5) Filters need to clean or not;
- 6) All doors and covers are put in right position;
- 7) If there is sundries left in the machine;
- 8) Air exhaust device is in good working condition.

#### **4.3.2 Start machine**

Please do the following steps to start the machine after finish the upper inspection;

**(Remarks: Please use tap water and start the machine to test 2~6 hours before adding clean liquid and start formal cleaning process to ensure the machine is installed right and all device in right condition.)**

- 1) Put stencil into cleaning room and close the front doors.
- 2) Set each parameters, such as clean and dry time.
- 3) Start air pump and add cleaning liquid to cleaning tank and reach the best liquid level according to liquid add in instructions.
- 4) Push “Start” key to start clean process.

#### **4.3.3 To ensure machine works properly, please do the following inspection after machine is started:**

- 1) Buttons or keys functions good or not.
- 2) Spray rotary device function is good or not.
- 3) Air pump function is good or not.
- 4) Pressure on pressure meters in normal working range or not.
- 5) Dry function is good or not.



- 6) Liquid pipes are sealed well, no liquid leak out.
- 7) Spray angle is the same or not.
- 8) Air exhaust device function is good or not.

#### **4.3.4 Shut off machine**

If you want to shut off this machine, please do the following actions:

- 1) Make sure cleaning and dry steps are finished
- 2) Check all cleaned parts are taken out from cleaning room.
- 3) Make sure Timers are reset to zero.

#### **4.4 MACHINE CLEAN METHOD AND PRECAUTIONS:**

There must be some oil or grease mixed into machine during transportation, installation and testing, please clean oil before using it to clean according to the following steps:

- 1) Using wet cloth to clean machine and then use dry cloth to clean it dry;
- 2) Add 1% dish wash detergent to liquid tank top level and start machine to clean for an hour and then discharge the used detergent.
- 3) Add tap water to liquid tank top level and start machine to clean for an hour and then discharge the used water.
- 4) Repeat step 3 and clean another 2 hours and discharge used water; after finish these steps, add cleaning liquid to tank best level and get prepared for formal clean process.

Please pay attentions to the following items during cleaning :

- 1) Put water before add dish wash detergent and add slowly and mix them up.
- 2) Check thoroughly to avoid used detergent or water leave in the machine;
- 3) Please do the upper steps to clean machine thoroughly and do rust prevention treatment when machine is stop and not used for a long time.

# 5 Operation instructions

## 5.1 OPERATIONAL PANEL

1) Control system overview: (Operational panel)

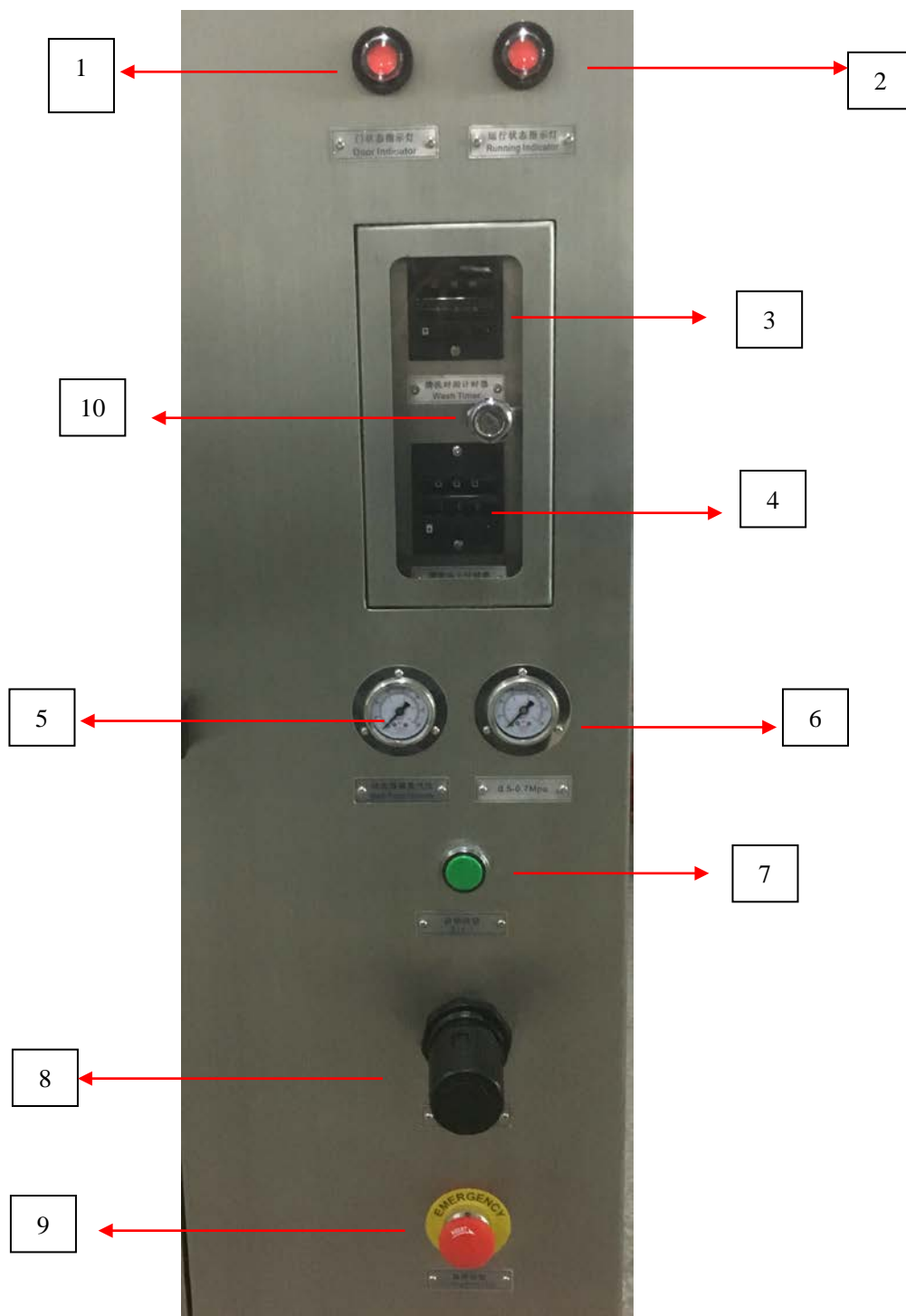

Operational control system include the following parts:

1. Door indicator: Door closed—green; door open—red.
2. Working situation indicator: machine working –green, machine stop—red.
3. Clean timer: Set clean time.
4. Dry timer: Set dry time.
5. Pressure meter: Air pump air pressure.
6. Pressure meter: Air supply pressure.
7. Start key: Start machine.
8. Cleaning liquid spray pressure regulator: Adjust cleaning pressure (Pull the cover out and then turn to adjust pressure you need, after finish adjusting, push it back and locked it again)
9. EMG button: Stop the machine or EMG stop the machine. (Please release it before start the machine)
10. Protection lock.

## 5.2 START TO OPERATE THE MACHINE

### 5.2.1 Cautions before operate the machine

To ensure the safety of the operator during machine operation and maintenance please obey to the following safety suggestions and rules:

- 1.1. Never operate this machine with the methods not written in this manual. If you have any questions, please contact us or our local agent for details.
- 1.2. The operator must know all the buttons' function on the panel and know how each mechanical devices works.
- 1.3. Any scattered parts or tools can not be put on the machine, the people who are in loose clothes or not bid long hairs, can not operate this machine.
- 1.4. For the operator or other people who will come into cleaning workshop, Never smoke or use mobile phone near the machine. Never carry any dangerous device to enter into cleaning workshop (such as lighter)
- 1.5. To avoid damaging this machine, never let the operator who are not trained well to operate this machine.
- 1.6. During operate the machine, be careful and must close the front door, put on protection glasses, gloves, masks to protect eyes and skins.

### 5.2.2 Preparations before start the machine:

- 
- 1.1 Check the static lines are connected well, the GND resistance is  $\leq 5\Omega$ .
  - 1.2 Connect the Air supply hose are connected well. (0.5-0.7Mpa/c m<sup>2</sup>)
  - 1.3 Check the exhaust pipe are connect well ( $\varnothing$  125mm exhaust hose lead to outside of the cleaning room.)
  - 1.4 Add enough cleaning liquid into the liquid tank ( 35)≡
  - 1.5 Put in stencil and push it to the inner side of cleaning room.

### 5.23 Operating method:

- A、 Watch the working conditions of all the parts on operational panel. Check air supply is OK.
- B、 Open the front door , put stencil into the cleaning room and close the door. At this time, door status indicator should turn green, if it is red, means door is not closed, you can not start the machine.

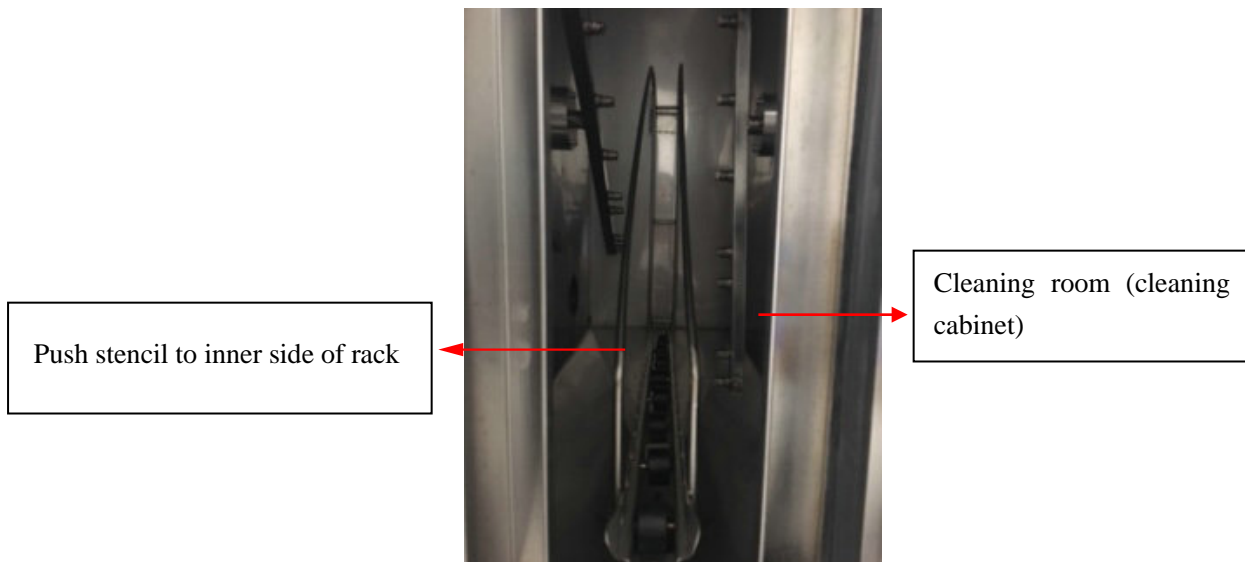

- C、 **Time setting:** (The min number is “1”. Never set it to”0”, even if you don’t use the timer, or else you can not start the machine.)

**Cleaning time setting:** Open the protection cover with screw driver, push the white key down according to the arrow (time lock key), at this time, push the 3 black keys to adjust time you want. (For black key, push 1 time, number cycling changes 1~9 each time). When you finger leave the white key, time setting is set and locked.

Time unit is second, normally clean time set to 240~999 seconds.



Manual reset key, put it turn 0

Time setting lock key

Time setting key, hundreds digit, tens digit, unit digit form right to left

**Never push or touch the timer with the finger with liquid, water or oil, or else it may destroy the time. Clean and dry finger is a must!!!**

**Dry time setting:** Open the protection cover with screw driver, push the white key down according to the arrow (time lock key), at this time, push the 3 black keys to adjust time you want. (For black key, push 1 time, number cycling changes 1~9 each time). When you finger leave the white key, time setting is set and locked.

Time unit is second, normally clean time set to 240~600 seconds.



Manual reset key, put it turn 0

Time setting lock key

Time setting key, hundreds digit, tens digit, unit digit form right to left

**D、** Release “EMERGENCY STOP”Key to working situation of it is pressed.(If you can not start the machine, please check this key, turn it clockwise to release.)

**E、** Push “START”key, machine start to work. cleaning timer start to count and start to clean stencil. When clean time reach to its setting time (for example 300). Cleaning action stops and shift to dry action automatically, Dry timer start to count and start to dry stencil. When dry time reach to its setting time (for example 320), the dry timer stops to count and machine stops immediately.

**F、** Open the door, machine resets ,take out stencil, one clean cycle is finished.

---

(wait for about 20~30sec to let rotary rods stops gradually, because of inertia)

**General instructions on add and discharge liquid:**

1. At the time of machine working : V1 and V2 should be open, Discharge liquid V3 and add liquid V4 should be closed; liquid flow from liquid tank—air pump—filter—cleaning room—liquid tank.
2. At the time of liquid adding: V1 and discharger liquid V3 should be closed; Valve 2 and add liquid V4 should be open: Liquid flow from liquid barrel—liquid add hose—air pump—filter—cleaning room—liquid tank.
3. At the time of discharge liquid: V2 and add liquid V4 should be closed; V1 and discharge liquid V3 should open. Waste liquid flow from: filter—liquid tank—air pump—discharge hose—waster liquid barrel
4. Liquid add or discharger speed is controlled by valve open scope; normally open the 2 valves little by little to control add or discharge speed, make sure liquid will not spray to your body and eyes. Be careful to hold the hoses firmly.
5. After finish liquid add or discharge action, **DO PLEASE turn all the valves to its normal working conditions ( Please refer to 1. At the time of machine working)** or else liquid will spray out or can not work.

If everything is ok, the machine still can not work, **please open the front door one time to reset the 2 timers and shut it off again.**

### 5.3 LIQUID ADD ACTION

Please confirm your personal protection tools your wear before adding liquid into cleaning tank.

- 1 Confirm the liquid type is right or not.
- 2 Confirm machine start condition and relevant device (close the front door and set enough liquid adding time,for example 900 sec).
- 3 Confirm liquid add valves is in right position or not
- 4 Insert liquid add hose into liquid barrel and ask another operator to push “start” key to start add liquid.
- 5 After finishing liquid add, stop the machine by push “EMG stop” key and return add liquid valves to its original position.

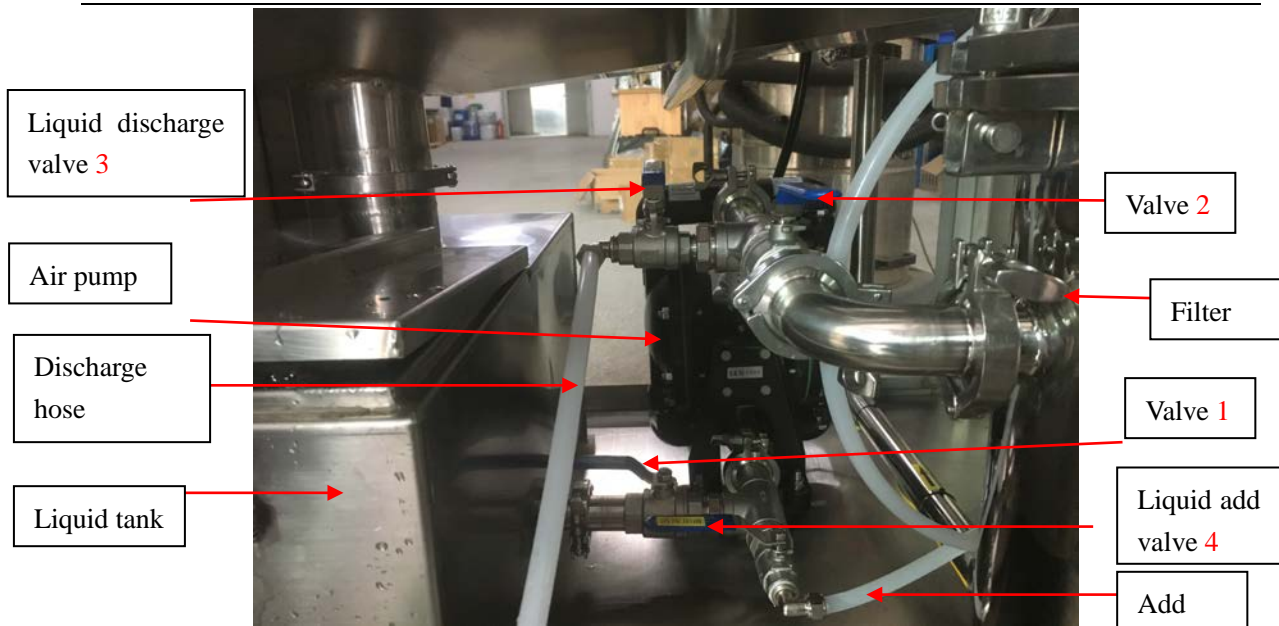

Valve 1,2,3,4 are ball valves, when valve pole and valve body is in 0 °, the valve is open; When valve pole and valve body is in 90°, the valve is close

#### 5.4 LIQUID DISCHARGE ACTION:

Please confirm your personal protection tools your wear before adding liquid into cleaning tank.

- 1 Confirm that you have enough waste liquid barrels.
- 2 Confirm machine start condition and relevant device (close the front door and set enough liquid adding time, (for example 900 sec).
- 3 Confirm liquid add valves is in right position or not
- 4 Insert liquid add hose into liquid barrel and ask another operator to push “start” key to start add liquid.
- 5 After finishing liquid add, stop the machine by push “EMG stop” key and return add liquid valves to its original position.

---

## 5.5 LIQUID TANK AND FILTER:

### A. Liquid add and discharge:

5.51 Special suggestion: Add cleaning liquid one time one week in normal working condition or you can add according to the real cleaning situation.

5.52 Please check cleaning liquid height on liquid tank, if it is lower than 20, you need to add cleaning liquid.

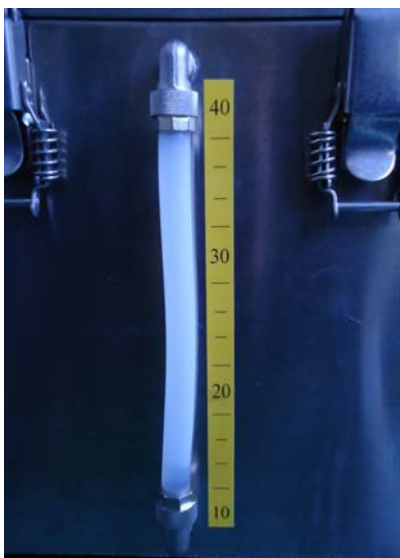

The highest liquid level is 40L

20L scale is the middle liquid level  
When Liquid level less than 20L , cleaning result will be affected , a this time, you need to add cleaning liquid

10L scale is the lowest liquid level, when it is lower than 10L scale, the liquid is not enough, the machine can not clean stencil as normal.

### B. Replace filter cartridge

5.53 After cleaning the machine for some time, filter cartridge need to be replaced (solder paste cleaning 2~3 months; red glue cleaning 1 week )





Flanged tighten screws

3 cartridges filter barrel

After discharging off liquid in cleaning tank and pipes --- lose 6 flanged screws on filter---take off the top SUS304 cover---lose 1 fixed screw and take out cartridge hold plate---take out 3 top white plastic top caps---take out 3 used filter cartridges---take out the 3 bottom white plastic caps.

After cleaning the filter barrel---put a bottom cap (2 holes on each end) into the holes in barrel---put on a new cartridge---put on a top cap(top end blocked, bottom end is hole), one by one, totally 3 cartridges---put back the cartridge hold plate and screw and tighten it ---Put on the top cover of filter barrel and tighten all 6 screws.(cartridge spec: 10 inch, 1um)



Top cover (top end blocked)

Filter cartridge

Bottom cover (2 holes on each end)

## 5.6 Air supply and exhaust

### 1、 Air supply

The air supply pressure should be 0.5~0.7Mpa, air flow should be 400~600L/Min, air inlet pipe should be bigger than 1/2", connect machine and pipe, please use air soft hose bigger than  $\varnothing$  12mm.(normally, we put one soft air hose in the machine)

### 2、 Ventilation and air exhaust

On the top of the machine, there is a  $\varnothing$  125mm vent, you need an individual air pipe to connect the vent and lead the compressed air out during dry process( pipe length should be less than 6 meters and less than 2 pcs 90°elbows, or else, you need to equip an air exhaust fan onto the other end of air pipe. Never connect the air pipe together with other pipes which connected on heat resources producing equipment. Hot air may cause fire or explosion on our cleaning machine when they meet solvent.

# 6 Maintenance

## 6.1 Maintenance sheet:

Device	No	Items	Maintenance procedures
Machine body	1	Machine outside clean	Wipe the machine with dry cloth with some WD-40
Cleaning system	1	Liquid tank clean	Start the machine
			Discharge the liquid off
			If it is dirty, clean it with clean cloth
			Close the discharge valve
	1	Filter net in the tank on air pump inlet hole	Take out the net and blow it with compressed air
	2	Filter bag, filter box clean	Lose the screw on steel box, put out box and take out plastic filter bag, clean the m and put them back, fix the screw.
Spray system	1	Nozzles	Disassembly the spray rotary rod off from machine by lose the 4 fix screws, take them out and pull the rotary device out
			Take off the screws with screw driver

			Tidy the nozzles and blow the rotary rod with compressed air to drive foreign matter out
			Clean bearings if necessary
			Put on nozzles and arrange them in the same angle 5~15°
Filter barrel	1	Cartridge replacement	Discharge liquid in the filter barrel
			Lose 6 screws, take off top cover, lose screw, take off plate, tank out old cartridges, replace them with 3 new one
			Put back plate and fix screw, put back top cover and fix the 6 screws

## 6.2 PRECAUTIONS ON MAINTENANCE

### 6.2.1 Rotary Spray Cleaning Device

- 1) Turn the rotary spray rods and check if it turns smoothly or not every month.
- 2) Check nozzles whether they are blocked or not, to avoid NG clean.
- 3) Rotary spray device are SUS304 material, special ceramic bearing and are well designed and processed.  
Don't worry about corrosion or rust.

### 6.2.2 Cleaning System

- 1) Start the air pump, inspect air pressure meter to check if it is lower than normal value, if it does, it means nozzles or filter are blocked by foreign matters.
  - \* disassembly and assembly nozzles:
    - a、 Spray rods disassembly: Open the front door, lose the 4 fixed screws and take the out, pull out the spray rod.
    - b、 Disassembly spray rod with an adjustable wrench if necessary.(normally no need)
    - c、 take off nozzles with wrench (cautions: nozzles are fixed with the same angles among 5~15°, for example same 10°we suggested) .
    - d、 Blow spray rods with compressed air and clean them with tap water.

### 6.2.3 Dry System

- 1) Suggest to check the air regulator once a day, whether the air supply is enough or whether there is air leak out.
- 2) Air filter in air regulator may covered with dusts, please take it off and clean it with compressed air to make it clean.
- 3) Nozzle set to the same best angles and well arranged, please don't adjust them casually.

### 6.2.4 Machine clean

- 1) Please clean machine every week.

## 6.3 MAINTENANCE CYCLE SHEET:

device	NO	Items	Maintenance cycle	Remarks
Machine out covers	1、	Machine out covers	Every week	
Liquid tank	1、	Filter net on air pump inlet hole	Every month	
		Filter bag and filter box	Every month	
Spray device	1、	Nozzle clean	Every month	
Filter	1、	Filter replacement	Every month	

# 7 Trouble shooting

## 7.1 SPRAY SYSTEM:

Trouble situation	Trouble reason	Trouble shooting
1、 Spray device do not rotate when start machine  2、 abnormal noises give out	a、 Spray device choked by foreign matters  b、 Nozzle blocked  c、 Air supply pressure is low  d、 Nozzles' angles are wrong  e、 Some fixing screws are loose	a、 Shut off the machine, take out foreign matters and restart it  b、 Clean nozzles  c、 Check air supply or air leak out  d、 Don't change the nozzle angle, as they are arranged well before shipping.  e、 Tighten loose screws

## 7.2 CLEANING SYSTEM:

Trouble situation	Trouble reason	Trouble shooting
1、 Start the machine, spray cleaning pressure is unstable	A、 Air pump liquid inlet hole filter net is blocked	A、 Clean the filter net
	B、 Nozzles are blocked	B、 take off nozzles and clean them
	C、 Liquid level low, liquid is not enough	C、 Add liquid to enough level
	D、 Air pump is broken	D、 Replace pump
	E、 Pressure meter is broken	E、 Replace meter
2、 Cleaning result NG	A、 Cleaning liquid NG	A、 Check cleaning liquid is correct or not or replace new liquid
	B、 liquid tank is too dirty, pollute the liquid	B、 Clean liquid tank
	C、 Liquid level low, liquid is not enough	C、 Add liquid to enough level
	D、 Air supply pressure is less than 0.5Mpa	D、 Increase air pressure
	E、 Water base cleaning liquid is foam type	E、 replace it with not foam type

## 8. Material sheet

### 8. MAIN SPARE PARTS:

S/N	ITEM	SPEC	AMOUNT
1	Air indicator	KIL-G	2
2	Safety valve	VZM550-01-00	1
3	Cylinder	CDJ2B16-100T-B	1
4	Muffler	Connect to air pump	1
5	Valves	PV8102	4
6	Valves	PV8103	1
7	Timer	HENSTLER	2
8	Protection cover	Acrylic	1
9	Air adjust valve	AR-4000-4	1
10	Air regulator	AW-4000-4	1
11	Angle set valve	KLJZF-15-SS	1
12	Angle set valve	KLJZF-15-SS	2
13	Air pump	INGERSOLL RAND1 INCH	1
14	Filter bag	Nylon	1
15	EMG stop button	MSV86522-EB	1
16	Start key	MSV86522-PP	1
17	Nozzle	SUS304 6505	22
18	Filter barrel	SUS304	1
19	Filter cartridge	10 inch, 1um	3
20	Rotary device	SUS304	2
21	Meters	Φ40-ZG1/8	2
22	Ball valves	1 inch	2
23	Ball valves	1/2 inch	2

---

## 9 Warranty terms

### 9.1 WARRANTY TIME:

- 1) One year after installation is the warranty time (Please take the acceptance date as standard, so as blow) ;
- 2) If machine arrived at customer's company, but not installed for 1 month, one year warranty time will be start from the beginning of second month.

### 9.2 GUARANTEE ITEMS:

- 1) **Guarantee:** Our company will be responsible to repair any parts free of charge if trouble happened in warranty time. Please write down your machine trouble in details and E-MAIL to [info@smthelp.com](mailto:info@smthelp.com) or phone no.: (86)-0755 83203237 to inform our after-sales department. Our after-sales department staff will analysis your machine trouble descriptions and offer service in time according to our guarantee permission.
- 2) Parts repair and technical support are free of charge under one year warranty. If you need our engineers to serve on site, please discuss (Consumable parts and parts damage caused by miss operation by operator are not include.)
- 3) **Guarantee duty:**

Our machine are carefully tested and inspected by our QC department. Our company will not have the duty to those troubles and damage caused by the following reasons. But you can choose compensable service.

  - A. Machine trouble or damage caused by mis-operation;
  - B. Improperly use or use not qualified spare parts or change air circuit, pneumatic parts and (software);
  - C. Consumable parts are not in the guarantee range, for example: filter cartridge, filter net, seal strip, customers can buy them from our company;
  - D. Troubles are not in guarantee range in “maintenance” and “spare parts replacement and repair” chapters of this manual;
  - E. Damage caused by improperly repair and incorrect parts;
  - F. The whole machine are expired warranty time;

---

G. Trouble and damage caused by force majeure (force majeure clauses: not foreseen and the results are unavoidable, insurmountable, such as war, heavy fire disaster, heavy flood, typhoon, earthquake... etc.)

H. Our company will charge on troubles which expiry warranty and not in guarantee range.

### 9.3 INSTRUCTION

- 1) This commitment is only suitable for PRC range, if other country law has other obligations on it, please obey the country law ;
- 2) Our company is responsible for the losses which caused by our engineers during repairing under warranty time.
- 3) Our company has the ownership of replaced spare parts under warranty;

**In Addition: This commitment only has effects on this machine. Other derivative problems are not in this range. If you have any questions, do please contact our company for solutions.**

## 10 Service range:

The selling amount (machine price) of this machine not include consumable parts and engineers onsite support costs. Our company will charge on the following situations even the machine is under warranty.

- 1 Installation, test and trial running of the machine.
- 2 Regular maintenance.
- 3 Educations on operation, process analysis.
- 4 Technical supports and educations on non-standard working flow.
- 5 other charge service which we confirmed.



# 11 Appendix

## 11.1 STRUCTURE CHART:

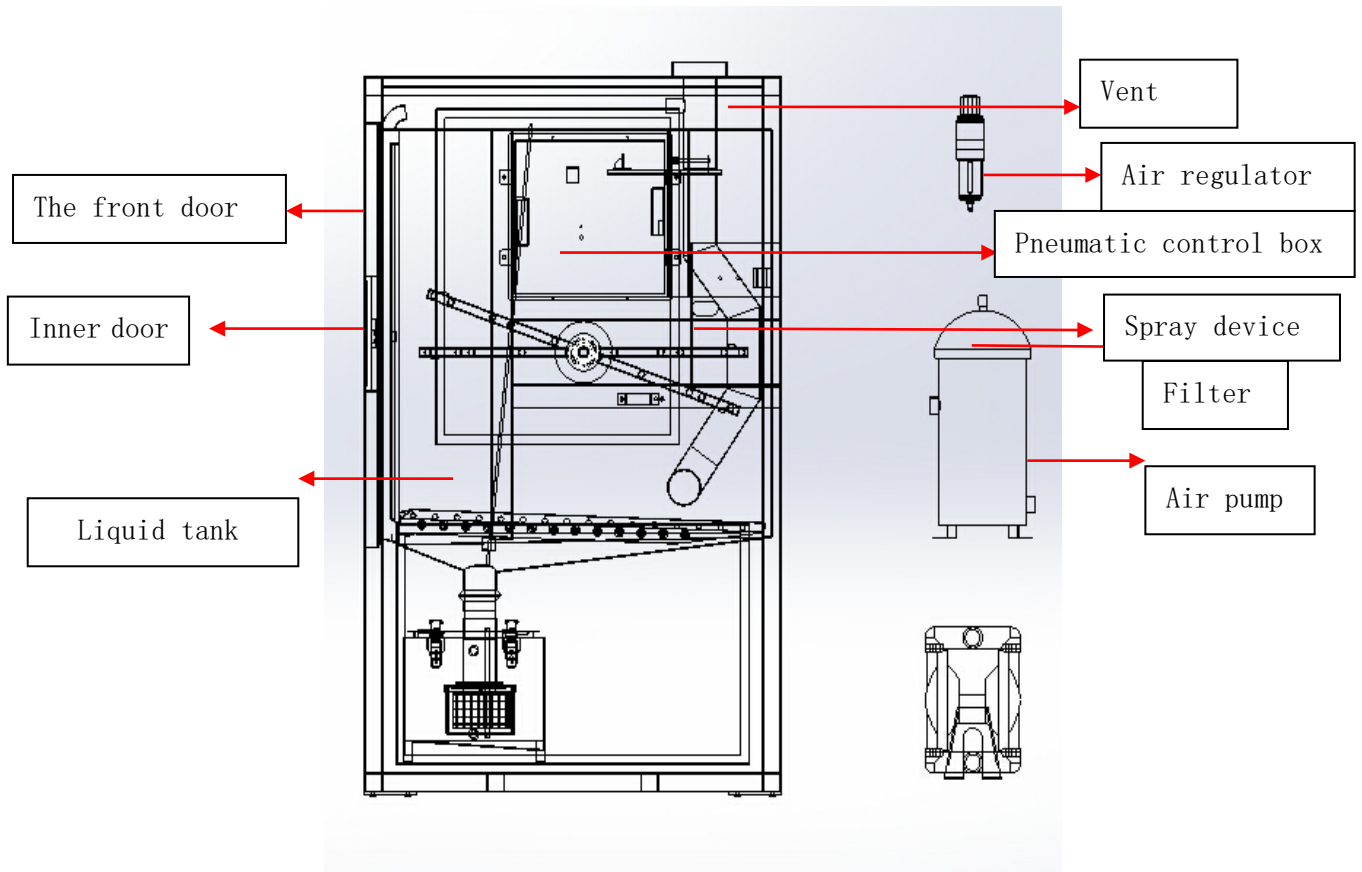

## 11.2 LIQUID FLOW CHART:

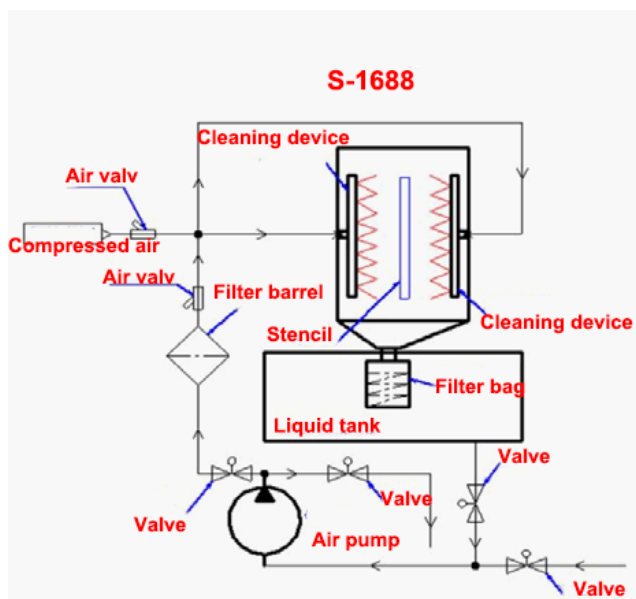

---

### 11.3 MACHINE PICTURE:



(Please take the real machine as standard for different version machine may has difference)

11.3 AIR CIRCUIT:

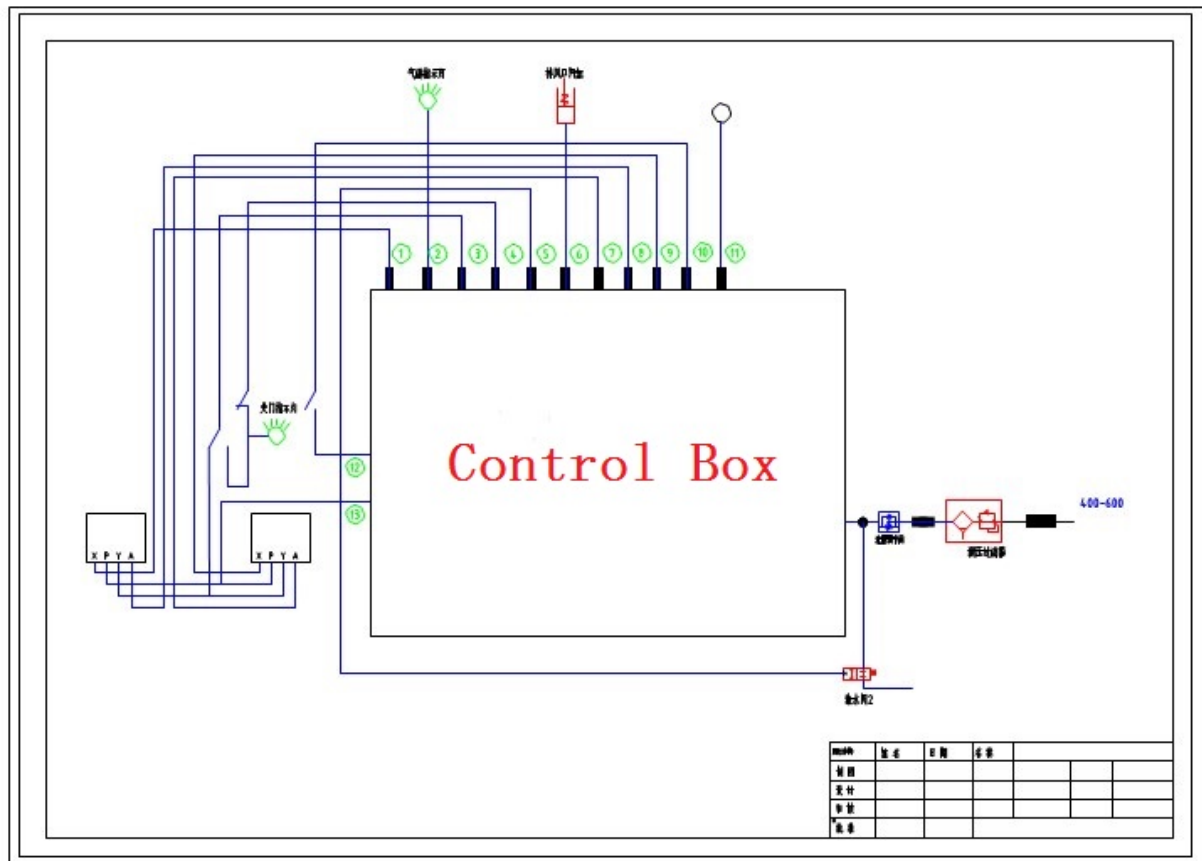



**SOUTHERN  
MACHINERY**

**Shenzhen Southern Machinery Sales And Service Co. Ltd**

Add:Rm1806,Block3,JinyunCOFCO,Qianjin-2<sup>nd</sup>Road,Xixiang,Baoan,SZ,518102,China  
TEL: 0755-83203237; Email:info@smthelp.com; Website:www.smthelp.com

---

## **24 HOURS TECHNICAL SUPPORT AND SERVICE!**

**If you has any technical questions, troubles or consumable material purchasing requirements, please contact us, our service line:**

**(86)-755-83203237 (China mainland) or contact our local agents or distributors.**